

**Class I**  
Drivetrains  
for Electric  
Counterbalance  
Lift Trucks

# Axles

## for Electric Counterbalance Trucks and Ground Support Equipment

### Applications

- › 4 wheel Electric CB Lift Trucks
- › Ground Support Equipment (Tow Tractors and Platform Trucks)

### Standard features

- › Drive Motor Coaxial with Axle
- › Wet Disc Parking Brake
- › Wet Disc Service Brake
- › Easy to service
- › Optimized installation envelope
- › Maintenance free
- › Optimized gears profile for noise reduction
- › Integrated must support

### Optional features

- › Mechanical actuation by lever of service brake
- › Complete powertrain solution

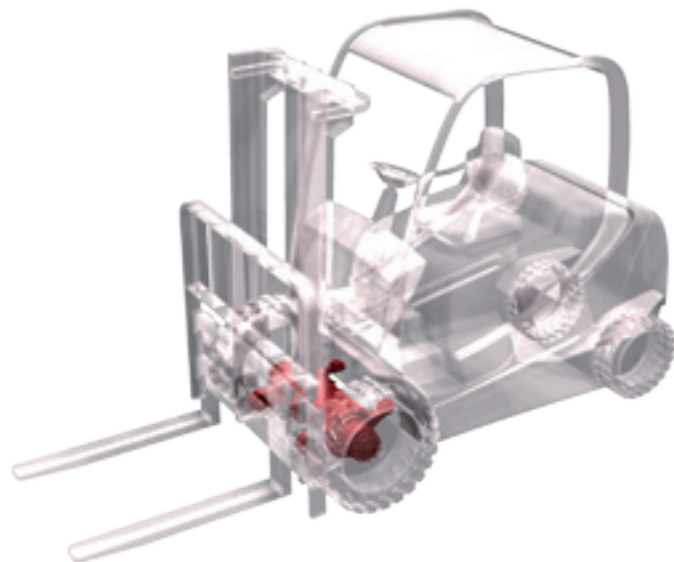

Class I

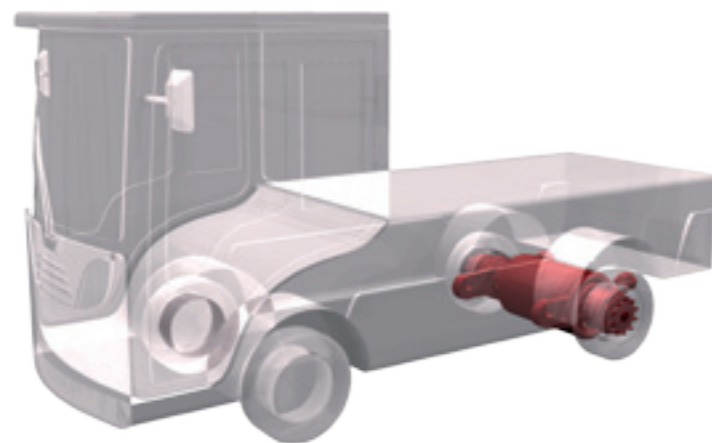

Class I / GSE

		EC 30 GSE	EC 35	EC 50
Trailer weight	Kg	25,000	-	-
Load capacity	Kg	3,000	8,800	12,000
Torque at wheels	Nm	4,800	5,200	6,500
Range of ratios		From 14:1 to 30:1	From 14:1 to 30:1	From 16:1 to 30:1
AC motor power Nom.	Kw	5/20	15	18
Parking Brake		Positive Mech Actuated	Positive Mech Actuated	Positive Mech Actuated
Applications		Ground support Equipment	4 wheel Electric CB Truck	4 wheel Electric CB Truck
<b>A</b> Final drive housing length	mm	178	173	182
<b>B</b> Differential length	mm	229	182	251
<b>C</b> Motor Housing length	mm	425	400	400
<b>D</b> Final drive diameter	mm	245	190	271
<b>E</b> Flange to flange distance	mm	1,076	Custom-made	Custom-made
<b>F</b> Wheel mounting	mm	170	170	225

