



Construction Equipment

Introduction

Carraro Group

Carraro is a multinational Group and world leader in power transmission systems. Its core business consists in conceiving, designing, validating, manufacturing and marketing drive systems for construction equipment, agricultural tractors, material handling, light commercial vehicles, automobiles, renewable energies and stationary applications (such as escalators and wind generators).

The Group, whose holding company Carraro Spa has been listed on the Italian Stock Exchange since 1995, is based in Campodarsego (Padua) and has manufacturing facilities in Italy, Germany, Argentina, the United States, India and China.

The Group Business Areas

CARRARO DRIVETECH

Integrated solutions (axles, transmissions, final & swing drives) for a wide range of applications: mining, construction equipment, agricultural tractors, light commercial vehicles, material handling and stationary applications (such as escalators & wind energy generators).

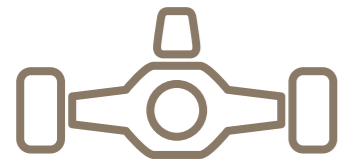

GearWorld

A Carraro Group Company

Low & high diameter steel gears, sinterized components and gears for earth-moving machines, agricultural tractors, cars, light commercial vehicles, two-wheel vehicles, power tools, garden equipment, railway and industrial applications, in particular for wind and solar energy.

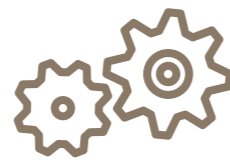

CARRARO AGRITALIA

Design and manufacturing of standard, vineyard & orchard tractors, from 50 to 100 HP; offering a wide range of engineering services, from simple consultancy to “turnkey” projects.

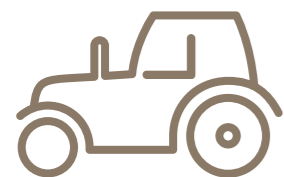

SANTERNO

CARRARO GROUP





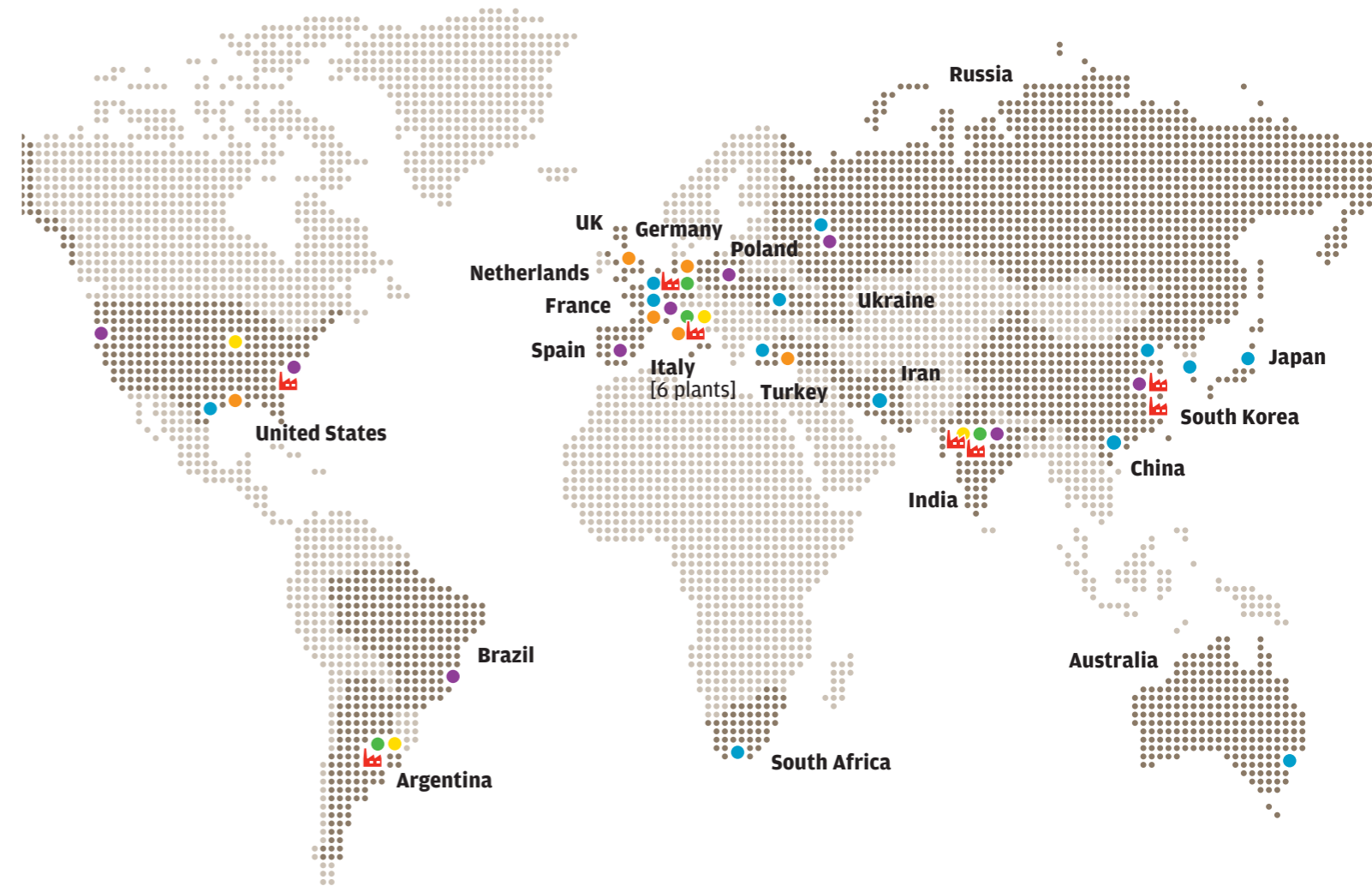

Inverters and power control, frequency converters, applied electronics for industrial plants, automation, renewable energies management (photovoltaic & wind energy), hybrid and electric vehicle powertrains.



Global footprint Where we are



HIGHLIGHTS

-  Manufacturing sites
-  Sales Offices
-  Engineering & Innovation Centers
-  Dealers
-  Service providers
-  Logistics & Spare Parts Centers

Carraro Drive Tech Drivelines & Drives

Carraro Drive Tech is the Business Unit managing the Carraro Group core business: designing, manufacturing and marketing drivelines, axles and transmissions, travel & cutter drives and electronic control units.

Wherever there is a need for integrated transmission systems for off- and on-highway vehicles, Carraro Drive Tech has the solution, with a complete, diversified product range for agriculture, construction equipment, mining, and material handling.

Carraro drivelines have been optimised for the individual markets of application, to guarantee the very best efficiency and most practical vehicle layout.

All this is possible thanks to the wide range of combinations of rigid and steering axles and mechanical, automatic or semi-automatic transmissions. The Carraro systems have been designed for the optimal integration of mechanics and hydraulics, under the supervision of an advanced electronic control unit. This can best manage the whole driveline while monitoring and diagnosing the vehicle functions.

Our solutions

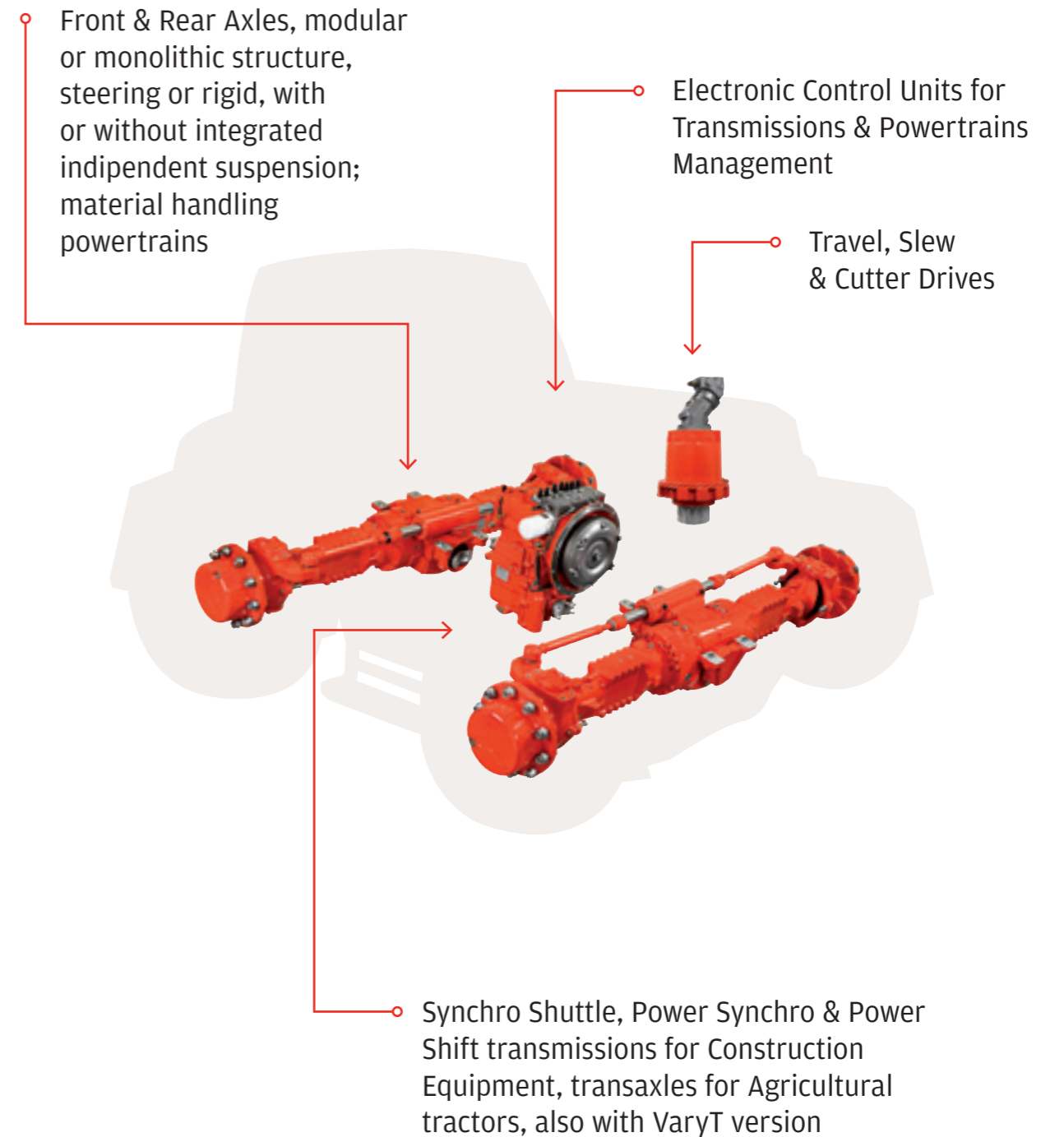

Carraro Drive Tech

Drivelines for Construction Equipment Applications

Thanks to a solid, long-lasting collaboration with major international constructions of off-highway applications, Carraro Drive Tech has now developed a consolidated know-how in the development of integrated systems devoted to all applications in the construction equipment sector, firmly positioning itself as a highly reliable full-liner partner.

An appropriate combination of transmissions, axles and drives today allows Carraro to offer a complete range for backhoe loaders, forklift trucks, wheel loaders, excavators, compactors, tracked vehicles and other wheeled and tracked applications.

The skills developed in power electronics further allow Carraro Drive Tech to integrate their transmission systems with evolved management solutions as a guarantee of an efficient integration of drivelines.

The full control of the system allows for the best possible management of the ergonomics and simplicity of use by the end user, at the same time also improving the efficiency of the entire system both in terms of productivity and reduction of machine consumption.

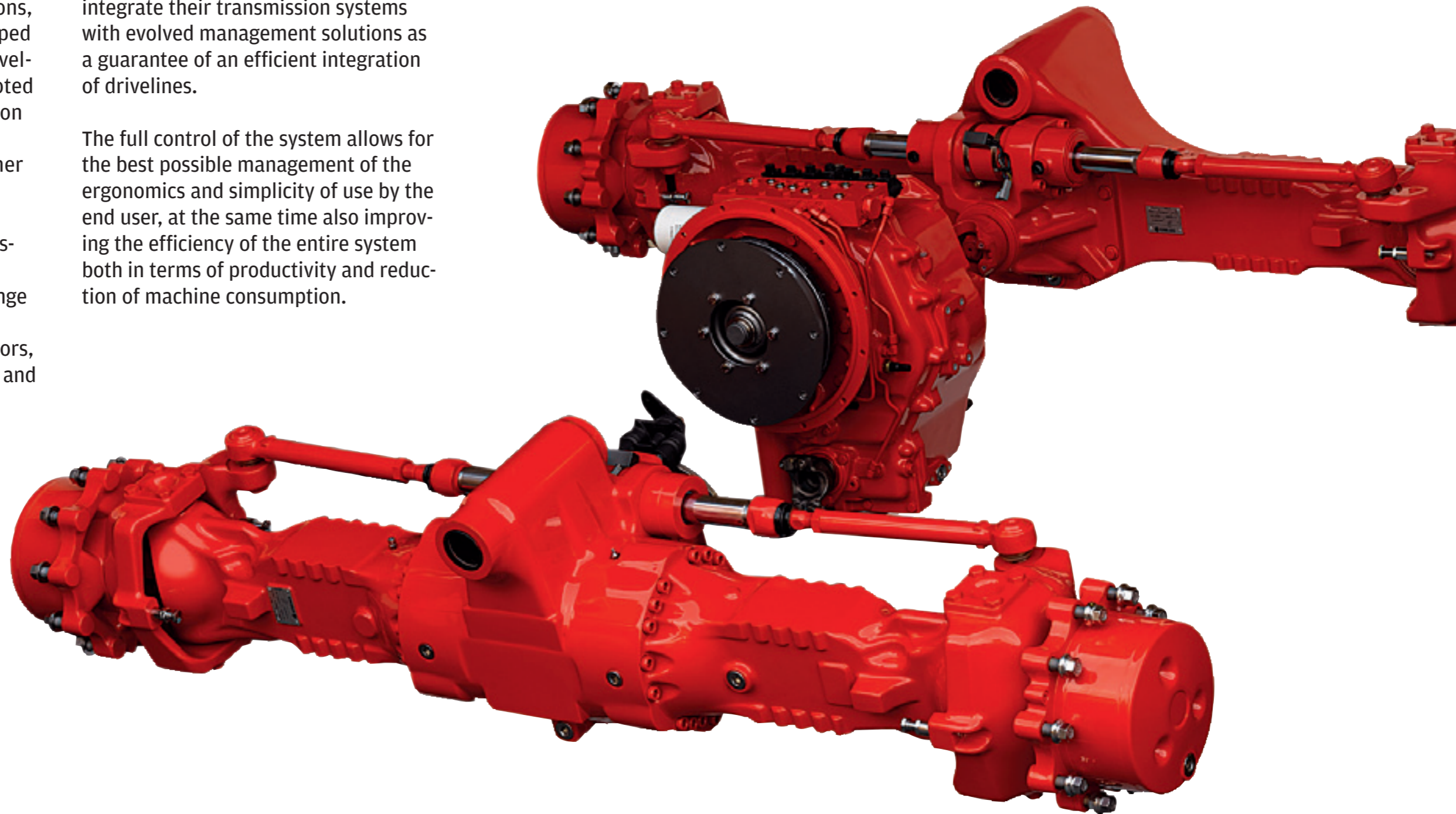

Transmissions

Hydrostatic Transmissions

| MODEL | | TB172 | TB172/2 |
|-------------------------|-----|---|---------------------------------|
| Description | | Single speed | Two speed synchro |
| Output drop from engine | mm | 172 | 172 |
| Input interfaces cc | | Hydraulic motors | Hydraulic motors |
| | | 80/160 | 80/160 |
| | | SAE 1410/1480 | SAE 1410/1480 |
| | | DIN 13010/1410 | DIN 1410 |
| Reduction ratios | | 2.750:1 | 1 st 2 nd |
| | | 2.031:1 | 4.286:1 1.359:1 |
| | | 1.853:1 | 2.971:1 1.273:1 |
| | | 1.553:1 | |
| | | 1.545:1 | |
| | | 1.179:1 | |
| Max Input | rpm | 5,500 | 5,500 |
| Max Input torque | Nm | 1,100 | 1,100 |
| Park brake type | | Dry discs manual control ball and ramp type | |
| Note | | TB172/2 is available in two versions: Stop&Go and Speed Shift | |

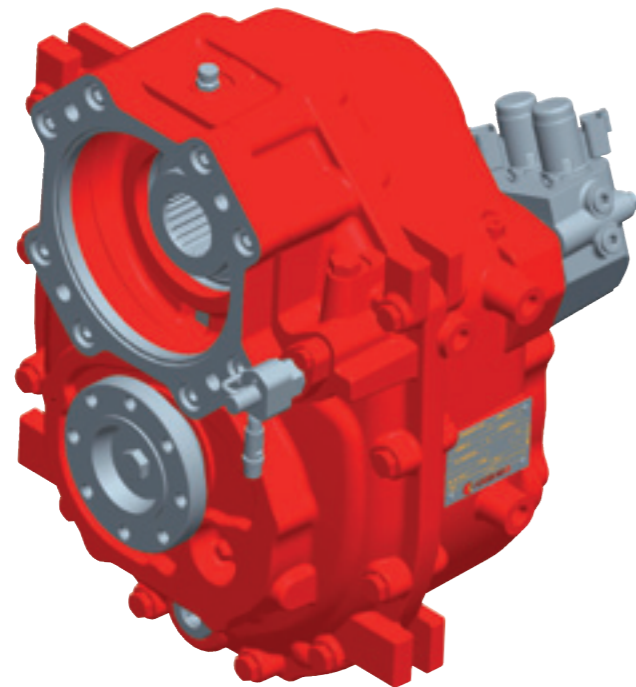

Hydrostatic Powershift Transmissions

| MODEL | | CV2 | FLS 3.2 | LS 4.2 |
|-------------------------|-----------------|---------------------|---------------------|---------------------|
| Description | | 2 speed power shift | 2 speed power shift | 2 speed power shift |
| Output drop from engine | mm | 182 | 185 | 176 |
| Input interfaces cc | | Hydraulic motor | Hydraulic motor | Hydraulic motor |
| | | 80/107 | 107 | 80/140 |
| Reduction ratios | 1 st | 2 nd | 1 st | 2 nd |
| | 9.137:1 | 2.400:1 | 4,217 | 1.022 |
| | 4.310:1 | 1.132:1 | | |
| | | | 5.143:1 | 1.371:1 |
| | | | 4.423:1 | 1.179:1 |
| Max Input | rpm | 5,500 | 5,500 | 5,500 |
| Max Input torque | Nm | 770 | 770 | 1,100 |
| Park brake type | | Wet Inboard SAHR | | |

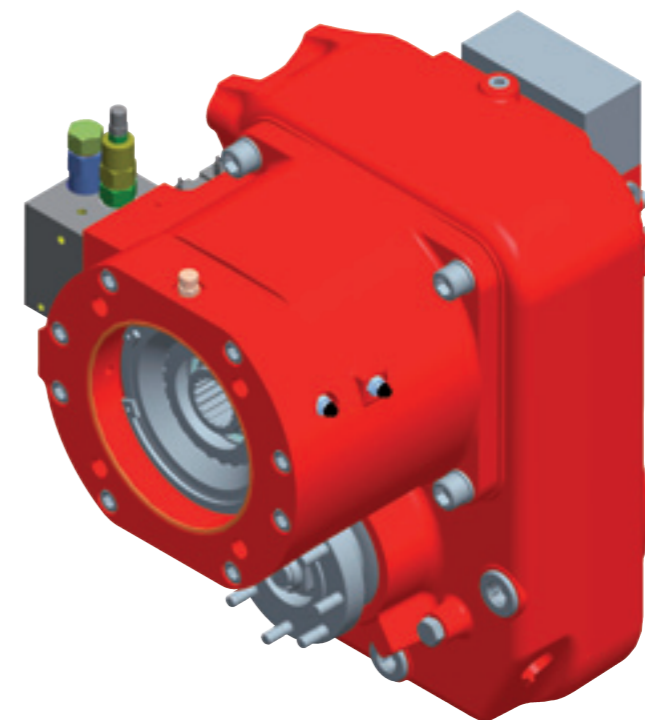

Torque Converter Transmissions Synchro Shuttle

| MAIN TECHNICAL DATA | TLB1 2WD | TLB1 4WD |
|-----------------------------|--|--|
| Power Rating | 82 kW @ 2,200 rpm | 82 kW @ 2,200 rpm |
| Max input Torque | 750 Nm | 750 Nm |
| Max input speed | 2,400 rpm | 2,400 rpm |
| Internal Pump Type | Gear | Gear |
| Engine Flywheel Interface | SAE 3 | SAE 3 |
| Output Flage Type | Yoke 1410 | Yoke 1410 |
| 2WD output drop from Engine | 180 mm | 180 mm |
| 4WD output drop from Engine | - | 323 mm |
| Vehicle Pump Interface | SAE C | SAE C |
| Torque Converter Size | W300 | W300 |
| Speed Gear | 4 Fwd + 4 Rev | 4 Fwd + 4 Rev |
| Fwd/Rev Ratios Option | 1:1 / 1:0.829 | 1:1 / 1:0.829 |
| Fwd Speed Gear Ratios | 1 st 2 nd 3 rd 4 th 5.603:1 3.481:1 1.585:1 0.793:1 | 1 st 2 nd 3 rd 4 th 5.603:1 3.481:1 1.585:1 0.793:1 |
| MFD Ratio Options | - | 0.8:1 / 0.818:1 / 0.895:1 |
| Electronic Control | No | No |
| Reverser | Power Reverse | Power Reverse |
| Gear Shifting | Synchro Shuttle | Synchro Shuttle |
| MFD Connection Options | - | SAHR Dog Clutch / SAHR Collar Shift |
| Parking Brake Options | None / SAHR Wet Discs / Manual Wet Discs | None / SAHR Wet Discs / Manual Wet Discs |
| Spin-On Oil Filter Options | Horizontal / Vertical / Remote | Horizontal / Vertical / Remote |
| Electric System Voltage | 12V | 12V |
| Differential Lock Solenoid | On Control Valve Assy | On Control Valve Assy |
| Power Brake in/out Ports | 15 bar nom. | 15 bar nom. |
| Speed Sensor | Available | Available |
| Temperature Sensor | Available | Available |
| Pressure Sensor | Available | Available |
| Electrical Harness | N/A | N/A |

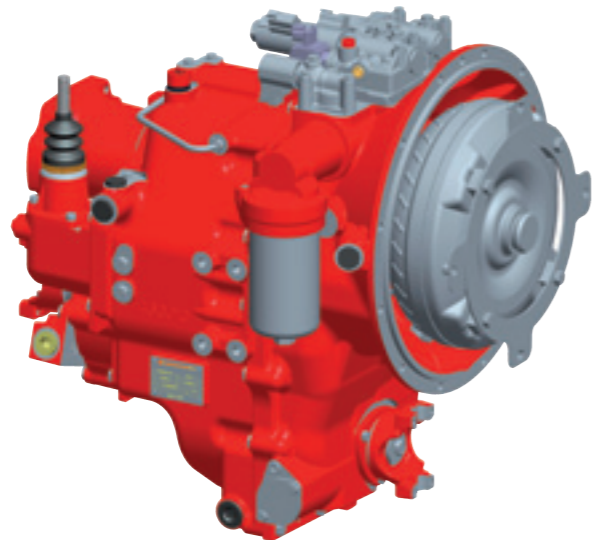

Torque Converter Transmissions Power Synchro

| MAIN TECHNICAL DATA | TLB1 SPS | TLB1 SPS Coaxial |
|-----------------------------|--|--|
| Power Rating | 82 kW @ 2,200 rpm | 82 kW @ 2,200 rpm |
| Max input Torque | 750 Nm | 750 Nm |
| Max input speed | 2,400 rpm | 2,400 rpm |
| Internal Pump Type | Gear | Gear |
| Engine Flywheel Interface | SAE 3 | SAE 3 |
| Output Flage Type | Yoke 1410 | Yoke 1410 |
| 2WD output drop from Engine | 180 mm | 180 mm |
| 4WD output drop from Engine | 323 mm | 334 mm |
| Vehicle Pump Interface | SAE C | SAE C |
| Torque Converter Size | W300 | W300 |
| Speed Gear | 4 Fwd + 4 Rev | 4 Fwd + 4 Rev |
| Fwd/Rev Ratios Option | 1:1 / 1:0.829 | 1:1 / 1:0.829 |
| FWD Speed Gear Ratios | 1 st 2 nd 3 rd 4 th 5.603:1 3.481:1 1.585:1 0.793:1 | 1 st 2 nd 3 rd 4 th 5.603:1 3.481:1 1.585:1 0.793:1 |
| MFD Ratio Options | 0.8:1 / 0.818:1 / 0.895:1 | 1:1 |
| Electronic Control | Yes | Yes |
| Reverser | Power Reverse | Power Reverse |
| Gear Shifting | Servo Power Synchro | Servo Power Synchro |
| MFD Connection Options | SAHR Dog Clutch / SAHR Collar Shift SAHR Wet Clutch | Permanent / SAHR Dog Clutch SAHR Collar Shift / SAHR Wet Clutch |
| Parking Brake Options | None / SAHR Wet Discs / Manual Wet Discs | None / SAHR Wet Discs / Manual Wet Discs |
| Spin-On Oil Filter Options | Vertical / Remote | Vertical / Remote |
| Electric System Voltage | 12V | 12V |
| Differential Lock Solenoid | On Control Valve Assy | On Control Valve Assy |
| Power Brake in/out Ports | 15 bar nom. | 15 bar nom. |
| Speed Sensor | Yes | Yes |
| Temperature Sensor | Yes | Yes |
| Pressure Sensor | Yes | Yes |
| Electrical Harness | Available | Available |

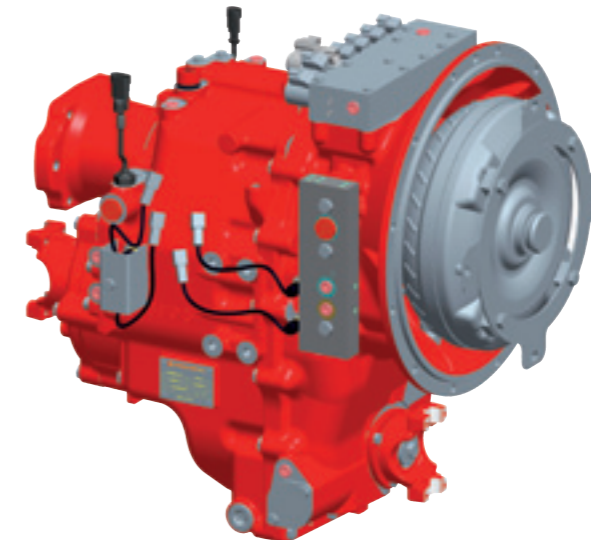

Torque Converter Transmissions Power Shift

| MAIN TECHNICAL DATA | TLB2 | TLB2 Coaxial | | | |
|-----------------------------|---|--|-----------------|-----------------|-----------------|
| Power Rating | 82 kW @ 2,200 rpm | 82 kW @ 2,200 rpm | | | |
| Max input Torque | 750 Nm | 750 Nm | | | |
| Max input speed | 2,400 rpm | 2,400 rpm | | | |
| Internal Pump Type | Gear | Gear | | | |
| Engine Flywheel Interface | SAE 3 | SAE 3 | | | |
| Output Flage Type | Yoke 1410 | Yoke 1410 | | | |
| 2WD output drop from Engine | 188 mm | 188 mm | | | |
| 4WD output drop from Engine | 350 mm | 350 mm | | | |
| Vehicle Pump Interface | SAE C | SAE C | | | |
| Torque Converter Size | W300 | W300 | | | |
| Speed Gear | 4 Fwd + 4 Rev | 4 Fwd + 4 Rev | | | |
| Fwd/Rev Ratios Option | 1:1 / 1:0.829 | 1:1 / 1:0.829 | | | |
| FWD Speed Gear Ratios | 1 st 2 nd 3 rd 4 th | 1 st | 2 nd | 3 rd | 4 th |
| | | 5.533:1 | 3.359:1 | 1.533:1 | 0.811:1 |
| MFD Ratio Options | 0.804:1 | 1:1 | | | |
| Electronic Control | Yes | Yes | | | |
| Reverser | Power Reverse | Power Reverse | | | |
| Gear Shifting | Power Shift | Power Shift | | | |
| MFD Connection Options | SAHR Wet Clutch | Permanent / SAHR Wet Clutch | | | |
| Parking Brake Options | None / SAHR Wet Discs / Manual Wet Discs | None / SAHR Wet Discs / Manual Wet Discs | | | |
| Spin-On Oil Filter Options | Horizontal / Vertical / Remote | Horizontal / Vertical / Remote | | | |
| Electric System Voltage | 12V | 12V | | | |
| Differential Lock Solenoid | On Control Valve Assy | On Control Valve Assy | | | |
| Power Brake in/out Ports | 15 bar nom. | 15 bar nom. | | | |
| Speed Sensor | Yes | Yes | | | |
| Temperature Sensor | Yes | Yes | | | |
| Pressure Sensor | Yes | Yes | | | |
| Electrical Harness | Available | Available | | | |

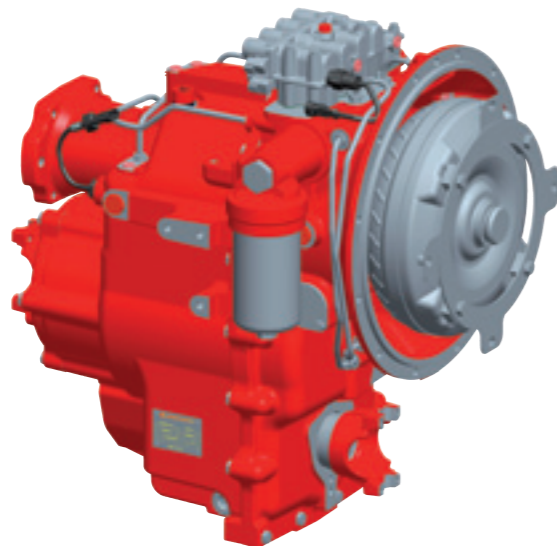

Electronic Control Unit

TRAX

Transmission Advanced Control System

| | |
|--------------------------------------|---|
| Transmission management mode | Semiautomatic: management by driver Automatic: full automatized gearshift |
| Vehicle responsiveness customization | Smooth or direct clutch modulation Configurable software by customers needs |
| Prevention autodiagnostic system | Alarm / Error signal for excessive working parametres and wrong inputs / Safety Management SIL1/ISO13849 Perf. level C |
| Auxiliary functions | Differential lock and steering sensor control Data interchange with electronic dashboard platform, CAN J1939, Serial line diagnostic and servicing |

General

| | |
|-----------------------|----------------|
| Operating Temperature | - 40 / + 85 °C |
| Storage Temperature | - 40 / + 85 °C |
| Protection Rating | IP 67 |

Electrical

| | |
|--------------------------------|---|
| Nominal Supply Voltage | 12 Vdc |
| Analog Voltage Input Range | 0 / 5 Vdc |
| Rated Digital Output Current | 2 A |
| Rated PWM Output Current | 2 A |
| Rated PWM Output Frequency | 4 kHz |
| Superimposed Dither Frequency | SW-adjustable |
| Superimposed Dither Amplitude | SW-adjustable |
| Serial Interface Communication | RS232, asynchronous, one CAN interface according to SAE J1939 / ISO 11783 / ISO 11898 |

Housing

| | |
|------------------------|--------------------------------|
| Electrical Connections | 56 pins board-mounted |
| Housing Material | High temperature nylon (Black) |
| Weight | 0.25 Kg (for reference only) |

Drivelines

Backhoe loaders drivelines

| 2WS machine Engine power kW | Front axle | Rear axle | Transmission |
|---------------------------------------|-------------------|---------------------|---------------------|
| From 50 up to 70 | 26.16 | 28.32 M 28.40 FR | TLB1 |
| From 71 up to 77 | 26.22 | 28.43 M 28.44 FR | TLB1 SPS |
| From 78 up to 88 | 26.24 | 28.50 FR | TLB2 |

| 4WS machine Engine power kW | Front axle | Rear axle | Transmission |
|---------------------------------------|-------------------|------------------|---------------------|
| From 71 up to 77 | 26.32 | 26.43 M | TLB1 SPS |
| From 78 up to 88 | 26.43 | 26.43 M | TLB2 |

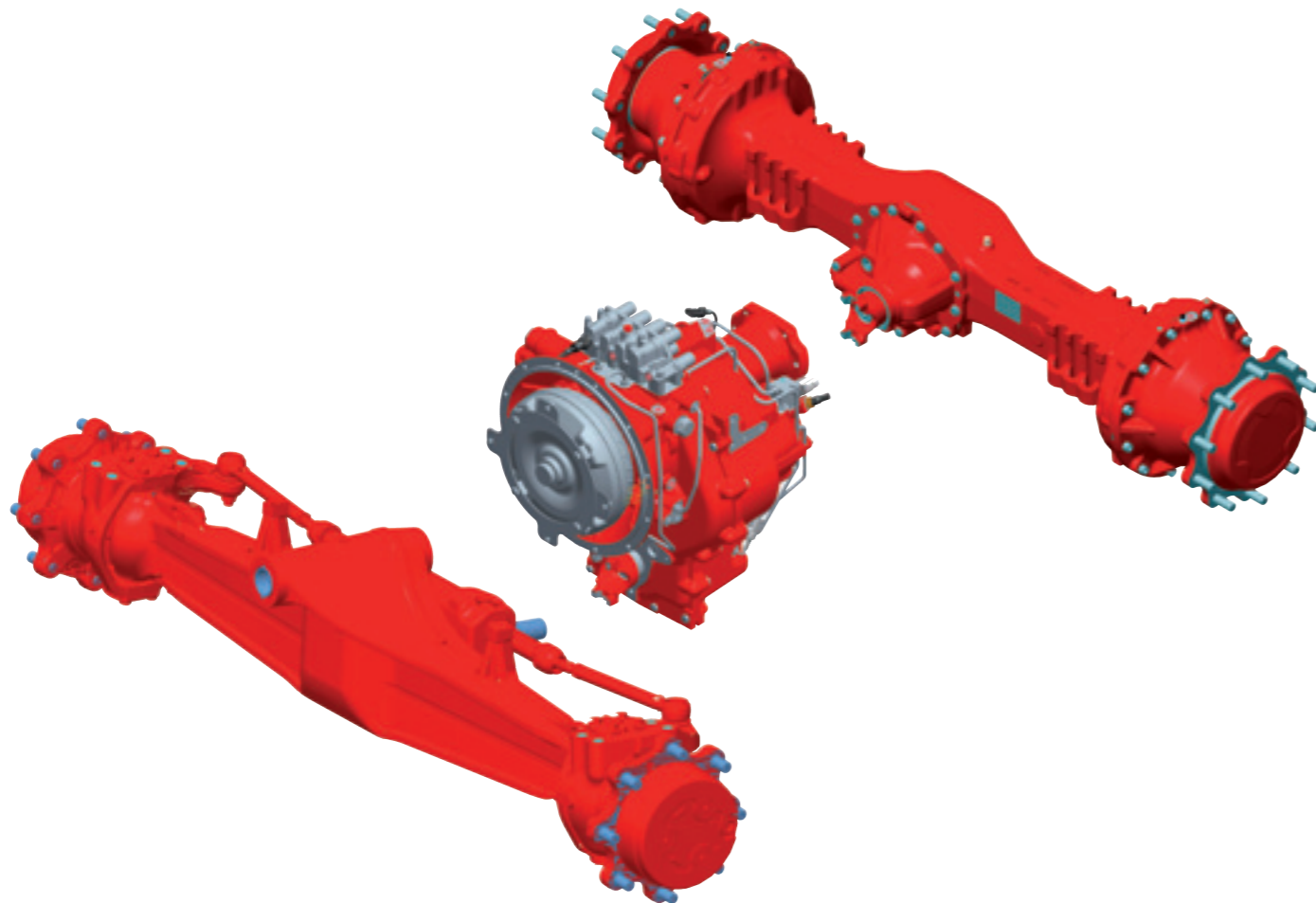

| 2WS BHL FRONT STEER MODEL | | | | | |
|----------------------------------|-----|-------------------------------|-----------------------------|-----------------------------|-----------------------------|
| MODEL | | 26.00 | 26.16 | 26.22 | 26.24 |
| Overall width | mm | 1,900 2,000 | 1,980 2,080 | 2,080 | 2,165 2,080 |
| Flange to flange distance | mm | 1,820 1,910 | 1,820 1,920 | 1,920 | 1,905 1,920 |
| Wheel mounting dimension | mm | n° 8 5/8"-18 on 203.2 mm ø | n° 8 M18x1.5 on 275 mm ø | n° 8 M18x1.5 on 275 mm ø | n° 8 M18x1.5 on 275 mm ø |
| Max steering angle | | 60° | 55° | 55° | 55° |
| Peak torque | kNm | - | 24 | 31 | 34 |
| Dynamic load capacity | kN | 80 | 80 | 95 | 95 |
| Static load capacity | kN | 200 | 200 | 237.5 | 237.5 |

| 2WS BHL REAR RIGID MODEL | | | | | | |
|---------------------------------|-----|------------------------------|------------------------------|------------------------------|------------------------------|------------------------------|
| MODEL | | 28.40 FR | 28.44 FR | 28.50 FR | 28.32 M | 28.43 M |
| Overall width | mm | 1,784 | 1,930 | 1,930 | 1,860 2,006 2,106 | 1,913 2,060 2,160 |
| Flange to flange distance | mm | 1,654 | 1,800 1,654 | 1,800 | 1,654 1,800 1,900 | 1,654 1,800 1,900 |
| Wheel mounting dimension | mm | n° 10 M22x1.5 on 335 mm ø | n° 10 M22x1.5 on 335 mm ø | n° 10 M22x1.5 on 335 mm ø | n° 10 M22x1.5 on 335 mm ø | n° 10 M22x1.5 on 335 mm ø |
| Peak torque | kNm | 56 | 62 | 70 | 45 | 60 |
| Dynamic load capacity | kN | 75 | 80 | 95 | 75 | 80 |
| Static load capacity | kN | 187.5 | 200 | 237.5 | 187.5 | 200 |

| 4WS BHL MODEL | | | | | |
|---------------------------|-----|------------------------------|------------------------------|------------------------------|------------------------------|
| MODEL | | 26.32 | 26.43 | 26.32 M | 26.43 M |
| Overall width | mm | 2,105 2,350 | 2,105 2,350 | 2,105 2,350 | 2,105 2,350 |
| Flange to flange distance | mm | 1,900 2,145 | 1,900 2,145 | 1,900 2,145 | 1,900 2,145 |
| Wheel mounting dimension | mm | n° 10 M22x1.5 on 335 mm ø | n° 10 M22x1.5 on 335 mm ø | n° 10 M22x1.5 on 335 mm ø | n° 10 M22x1.5 on 335 mm ø |
| Max steering angle | | 45° | 45° | 45° | 45° |
| Peak torque | kNm | 45 | 60 | 45 | 60 |
| Dynamic load capacity | kN | 90 | 100 | 75 | 100 |
| Static load capacity | kN | 225 | 250 | 187.5 | 250 |

Telehandlers drivelines

| Lift capacity kg | Front axle | Rear axle | Trasmission type |
|---------------------|------------|-----------|--|
| Up to 1,500 | 26.09M | 26.09M | TB135 Hydrostatic single speed |
| From 1,500 to 2,500 | 26.16M | 26.16 | TB172 Hydrostatic single speed TB172-2 Hydrostatic dual speed |
| From 2,500 to 3,000 | 26.20M | 26.20 | TB172 Hydrostatic single speed TB172-2 Hydrostatic dual speed |
| From 3,000 to 3,500 | 26.25M | 26.25 | TB172 Hydrostatic single speed TB172-2 Hydrostatic dual speed |
| From 3,500 to 4,000 | 26.27M | 26.27M | TB172 Hydrostatic single speed TB172-2 Hydrostatic dual speed TLB1 SPS four speed servo power synchro TLB2 four speed power shift |
| From 4,000 to 4,500 | 26.32M | 26.32M | TB172 Hydrostatic single speed TB172-2 Hydrostatic dual speed TLB1 SPS four speed servo power synchro TLB2 four speed power shift |
| From 4,500 to 5,000 | 26.43M | 26.43M | TB172 Hydrostatic single speed TB172-2 Hydrostatic dual speed TLB1 SPS four speed servo power synchro TLB2 four speed power shift |
| From 5,000 to 5,500 | 26.50M | 26.50M | TB172 Hydrostatic single speed TB172-2 Hydrostatic dual speed TLB1 SPS four speed servo power synchro TLB2 four speed power shift |

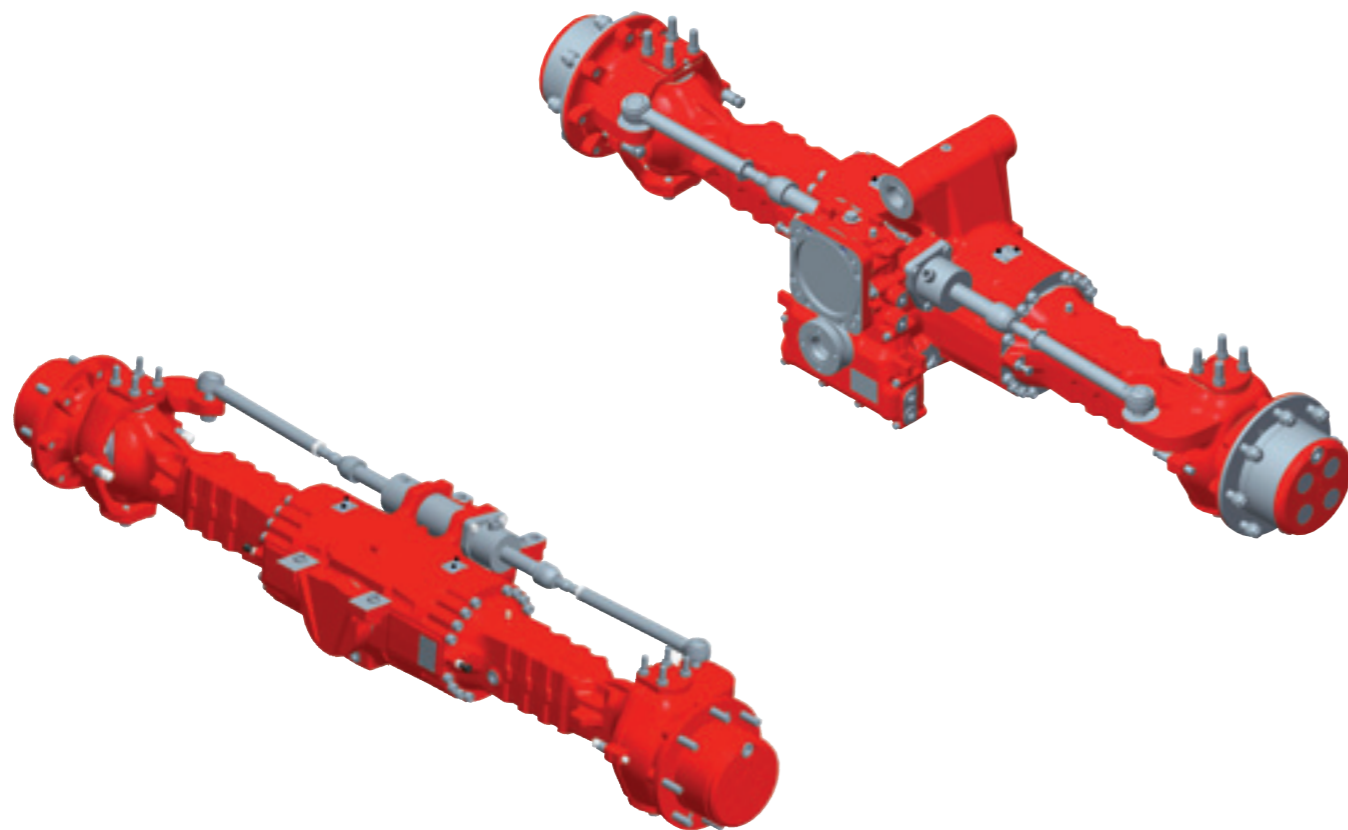

| MODEL | 26.09 | 26.16 | 26.20 | 26.25 |
|---------------------------|---|---|---|---|
| Flange to Flange distance | mm 1,155 1,247 | 1,640 | 1,580 1,640 1,680 1,800 1,900 | 1,832 1,932 |
| Wheel mounting dimension | n° 8 M18x1.5 on 203.5 mm ø | n° 8 M18x1.5 on 275 mm ø | n° 8 M18x1.5 on 275 mm ø | n° 8 M20x1.5 on 275 mm ø |
| Total ratio | 12.5:1 - 21.5:1 | 10.7:1 - 19.2:1 | 10.7:1 - 19.2:1 | 10.7:1 - 19.2:1 |
| Max steering angle | 40° | 40° | 40° | 45° |
| Brakes | Dry disc | Dry disc Wet multi-disc | Dry disc Wet multi-disc | Dry disc Wet multi-disc |
| Differential | Open Limited slip system Mechanical diff. lock | Open Limited slip system Mechanical diff. lock | Open Limited slip system Mechanical diff. lock | Open Limited slip system Mechanical diff. lock |
| Peak Torque | kNm 12 | 22 | 28 | 35 |
| Dynamic Load | kN 45 | 70 | 70 | 85 |
| Static Load | kN 112.5 | 175 | 175 | 212.5 |

| MODEL | 26.27 | 26.32 | 26.43 | 26.50 |
|---------------------------|---|---|---|---|
| Flange to Flange distance | mm 1,920 2,050 2,180 | 1,950 | 2,180 | 2,100 |
| Wheel mounting dimension | n° 8 M20x1.5 on 275 mm ø | n° 10 M22x1.5 on 335 mm ø | n° 10 M22x1.5 on 335 mm ø | n° 10 M22x1.5 on 335 mm ø |
| Total ratio | 14,3:1 - 23,3:1 | 17,1:1 - 23,3 | 17,1:1 - 23,3 | 23,0:1 |
| Max steering angle | 55° | 55° | 55° | 55° |
| Brakes | Dry disc Wet multi-disc | Dry disc Wet multi-disc | Dry disc Wet multi-disc | Dry disc Wet multi-disc |
| Differential | Open Limited slip system Mechanical diff. lock | Open Limited slip system Mechanical diff. lock | Open Limited slip system Mechanical diff. lock | Open Limited slip system Mechanical diff. lock |
| Peak Torque | kNm 37 | 44 | 60 | 70 |
| Dynamic Load | kN 85 | 105 | 105 | 125 |
| Static Load | kN 212.5 | 275 | 275 | 312.5 |

ALL MODELS AVAILABLE WITH

| | |
|----------------|--|
| Frame MTG | Center oscill. TRU Fixed pads |
| Service brakes | Wet immersed disc |
| Parking brake | SAUHR wet immersed disc Mechanical dry disc |

Wheel loaders axles

| Machine operative weight kg | Engine power kW | Front axle model | Rear axle model |
|--------------------------------|--------------------|------------------|-----------------|
| 7,000 | 70 | 28.32 | 28.32 |
| 8,500 | 81 | 28.44 | 28.44 |
| 10,000 | 96 | 28.56 | 28.56 |
| 12,500 | 118 | 28.64 | 28.64 |

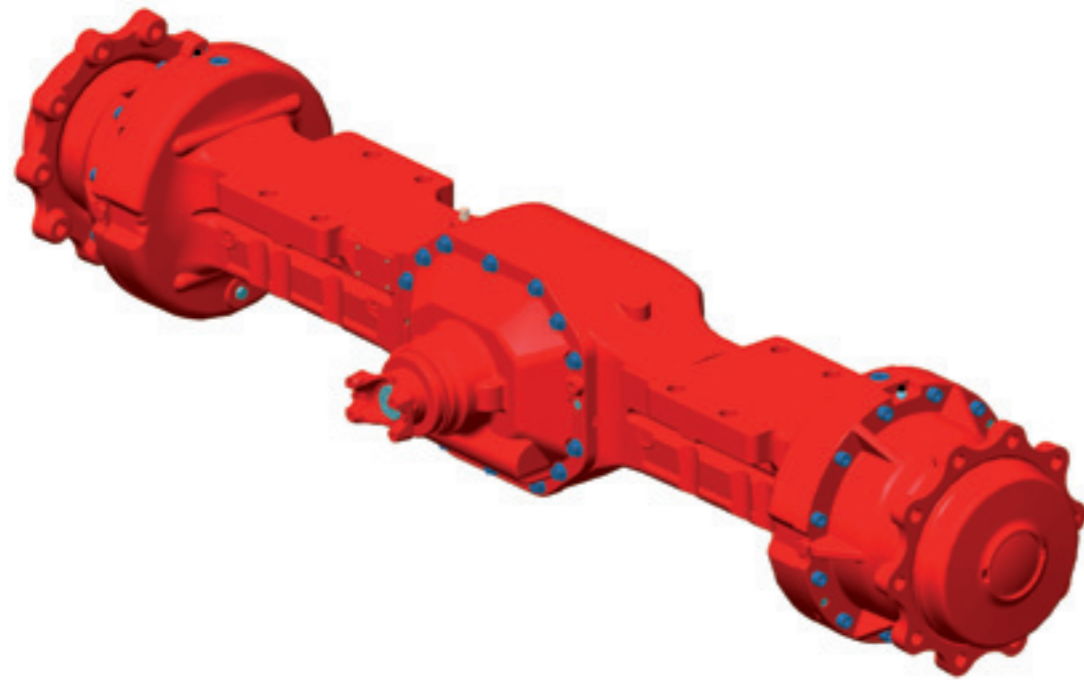

| MODEL | | 28.32 | 28.44 |
|---------------------------|-----|------------------------------|------------------------------|
| Overall width | mm | 2,050 | 1,930 |
| Flange to flange distance | mm | 1,800 | 1,800 |
| Wheel mounting dimension | mm | n° 10 M22x1.5 on 335 mm ø | n° 10 M22x1.5 on 335 mm ø |
| Peak torque | kNm | 44.8 | 62 |
| Dynamic load capacity | kN | 100 | 110 |
| Static load capacity | kN | 250 | 275 |

| MODEL | | 28.50 | 28.56 | 28.64 |
|---------------------------|-----|------------------------------|------------------------------|------------------------------|
| Overall width | mm | 1,930 | 2,070 | 2,070 |
| Flange to flange distance | mm | 1,800 | 1,930 | 1,930 |
| Wheel mounting dimension | mm | n° 10 M22x1.5 on 335 mm ø | n° 10 M22x1.5 on 335 mm ø | n° 12 M22x1.5 on 425 mm ø |
| Peak torque | kNm | 70 | 78 | 88 |
| Dynamic load capacity | kN | 110 | 120 | 140 |
| Static load capacity | kN | 275 | 300 | 350 |

ALL MODELS AVAILABLE WITH

| | |
|----------------|--------------------------------------|
| Frame MTG | Rigid with pads / Offset oscill. ACP |
| Service brakes | Wet immersed disc |

Mini & Compact wheel loaders axles

| Machine operative weight kg | Engine power kW | Front axle model | Rear axle model | Transmissions |
|--------------------------------|--------------------|------------------|-----------------|------------------------------------|
| Articulated Frame | | | | |
| 3,500 | 37 | 28.09 | 28.09 | TB135 / TB172 TB138-2 / TB172-2 |
| 5,500 | 51 | 28.16 | 28.16 | TB135 / TB172 TB138-2 / TB172-2 |
| 6,500 | 63 | 28.25 | 28.20 | TB135 / TB172 TB138-2 / TB172-2 |
| 7,500 | 66 | 28.28 | 28.28 | TB135 / TB172 TB138-2 / TB172-2 |
| Four Wheels Steering | | | | |
| 3,500 | 37 | 26.09 | 26.09 | TB135 / TB172 TB138-2 / TB172-2 |
| 5,500 | 51 | 26.16 | 26.16 | TB135 / TB172 TB138-2 / TB172-2 |
| 6,500 | 63 | 26.25 | 26.20 | TB135 / TB172 TB138-2 / TB172-2 |
| 7,500 | 74 | 26.28 | 26.28 | TB135 / TB172 TB138-2 / TB172-2 |

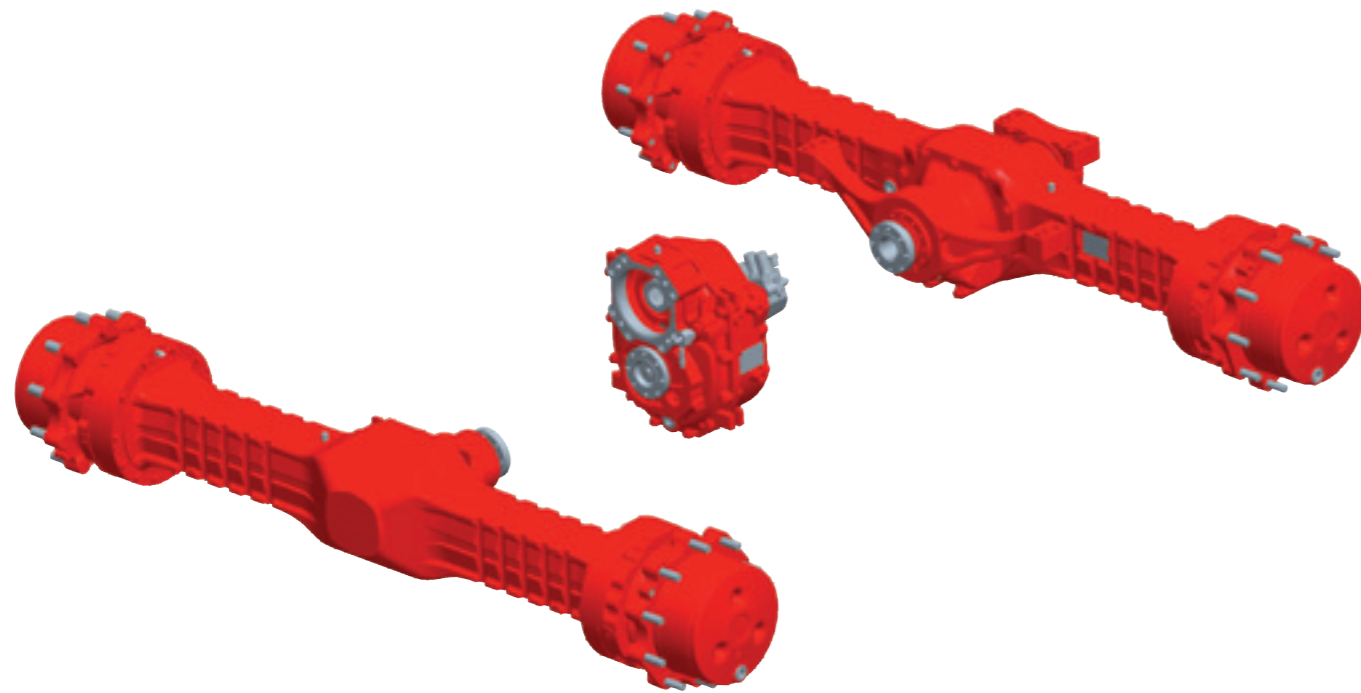

| MODEL | | 28.09 | 28.16 | 28.20 | 28.25 | 28.28 |
|---------------------------|-----|-----------------------------|-----------------------------|-----------------------------|-----------------------------|------------------------------|
| Articulated Frame | | | | | | |
| Overall width | mm | 1,400 1,550 | 1,550 1,650 | 1,570 1,810 1,910 | 1,570 1,810 1,910 | 1,640 1,840 1,940 |
| Flange to flange distance | mm | 1,250 1,400 | 1,400 1,500 | 1,430 1,570 1,760 | 1,430 1,570 1,760 | 1,430 1,630 1,730 |
| Wheel mounting dimension | mm | n° 6 M18x1.5 on 205 mm ø | n° 8 M18x1.5 on 275 mm ø | n° 8 M20x1.5 on 275 mm ø | n° 8 M20x1.5 on 275 mm ø | n° 10 M22x1.5 on 335 mm ø |
| Peak torque | kNm | 14 | 25 | 30 | 36 | 40 |
| Dynamic load capacity | kN | 40 | 55 | 90 | 90 | 100 |
| Static load capacity | kN | 100 | 137 | 225 | 225 | 250 |

| MODEL | | 26.09 C | 26.09 | 26.16 | 26.20 | 26.25 | 26.28 |
|----------------------------|-----|-----------------------------|-----------------------------|-----------------------------|-----------------------------|-----------------------------|------------------------------|
| Four wheel steering | | | | | | | |
| Overall width | mm | 1,125 | 1,320 | 1,660 | 1,660 1,800 | 1,660 1,800 | 1,935 2,155 |
| Flange to flange distance | mm | 1,020 | 1,155 | 1,500 | 1,500 1,640 | 1,500 1,640 | 1,680 1,900 |
| King pin distance | mm | 795 | 930 | 1,162 | 1,190 1,330 | 1,190 1,330 | 1,330 1,550 |
| Wheel mounting dimension | mm | n° 6 M18x1.5 on 205 mm ø | n° 6 M18x1.5 on 205 mm ø | n° 8 M18x1.5 on 275 mm ø | n° 8 M20x1.5 on 275 mm ø | n° 8 M20x1.5 on 275 mm ø | n° 10 M22x1.5 on 335 mm ø |
| Max steering angle | | 40° | 40° | 45° | 45° | 55° | 55° |
| Peak torque | kNm | 8.40 | 14.00 | 26.60 | 30.80 | 37.80 | 40.60 |
| Dynamic load capacity | kN | 40 | 45 | 65 | 80 | 80 | 90 |
| Static load capacity | kN | 100 | 112 | 162 | 200 | 200 | 225 |

ALL MODELS AVAILABLE WITH

| | |
|----------------|---|
| Frame MTG | Rigid with pads / Center oscill. TRU / Offset oscill. ACP |
| Service brakes | Single dry / Wet immersed disc |
| Parking brake | Ext. single dry |

Wheel Excavators drivelines

| Vehicle weight tons | Front axle model | Rear axle model | Transmission |
|------------------------|------------------|-----------------|-------------------------------|
| From 5 to 7 | 26.16 E | 28.16 E | TB 172 TB 172-2 |
| From 8 to 10 | 26.25 E | 28.25 E | TB 172 TB 172-2 |
| From 11 to 16 | 26.32 E | 28.32 E | FLS 3.2 LS 3.2 |
| From 17 to 19 | 26.44 E | 28.44 E | FLS 3.2 / 4.2 LS 3.2 / 4.2 |
| From 20 to 24 | 26.54 E | 28.54 E | FLS 4.2 LS 4.2 |

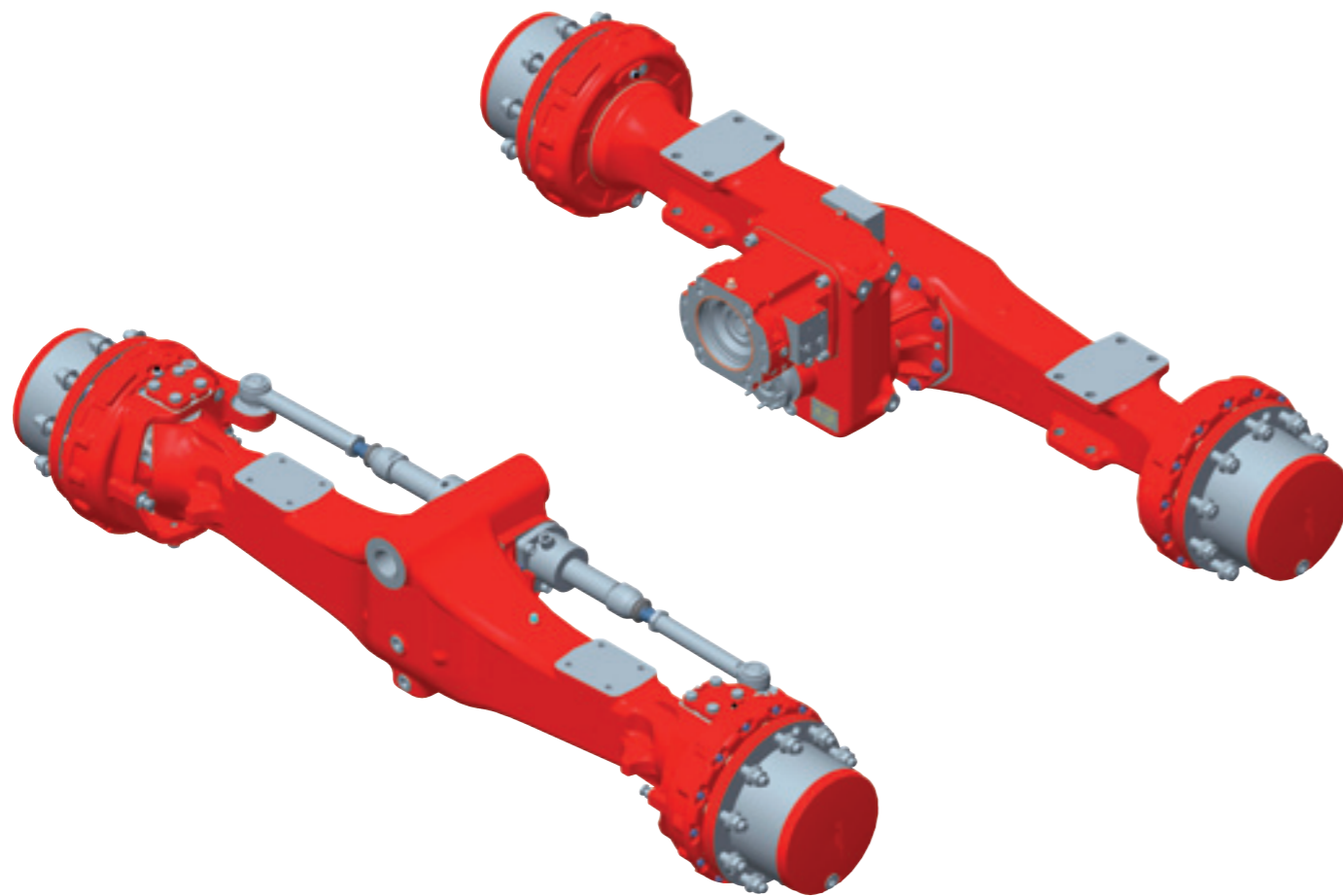

| MODEL | | 26.16 E | 26.25 E | 26.32 E | 26.44 E | 26.54 E |
|---------------------------|-----|--|--|------------------------------|------------------------------|------------------------------|
| Overall width | mm | 1,954 | 2,074 | 2,241 | 2,241 | 2,421 |
| Flange to flange distance | mm | 1,720 | 1,832 | 1,920 | 1,920 | 2,100 |
| Wheel mounting dimension | | n° 8 M18x1.5 on 275 mm ø or n° 8 M20x1.5 on 275 mm ø | n° 8 M18x1.5 on 275 mm ø or n° 8 M20x1.5 on 275 mm ø | n° 10 M22x1.5 on 335 mm ø | n° 10 M22x1.5 on 335 mm ø | n° 10 M22x1.5 on 335 mm ø |
| Max. steering angle | | 45° | 45° | 40° | 40° | 40° |
| Peak torque | kNm | 22 | 35 | 45 | 54 | 68 |
| Dynamic load capacity | kN | 70 | 85 | 95 | 120 | 150 |
| Static load capacity | kN | 175 | 212.5 | 237.5 | 300 | 380 |

| MODEL | | 28.16 E | 28.25 E | 28.32 E | 28.44 E | 28.54 E |
|---------------------------|-----|--|--|------------------------------|------------------------------|------------------------------|
| Overall width | mm | 1,954 | 1,980 | 2,241 | 2,241 | 2,421 |
| Flange to flange distance | mm | 1,720 | 1,838 | 1,920 | 1,920 | 2,100 |
| Wheel mounting dimension | | n° 8 M18x1.5 on 275 mm ø or n° 8 M20x1.5 on 275 mm ø | n° 8 M18x1.5 on 275 mm ø or n° 8 M20x1.5 on 275 mm ø | n° 10 M22x1.5 on 335 mm ø | n° 10 M22x1.5 on 335 mm ø | n° 10 M22x1.5 on 335 mm ø |
| Peak torque | kNm | 22 | 35 | 45 | 54 | 68 |
| Dynamic load capacity | kN | 80 | 85 | 95 | 120 | 150 |
| Static load capacity | kN | 200 | 212.5 | 237.5 | 300 | 380 |

ALL MODELS AVAILABLE WITH

| | |
|----------------|---|
| Frame MTG | Rear: Rigid with pads / Front: Offset oscill. ACP |
| Service brakes | Wet immersed disc acting "on wheel" for WE axles |

Note

In addition to the driveline Carraro also offers a full range of slew drives for rotation of the excavator's upper carriage.

Soil compactor axles

| Vehicle weight tons | Rear axle model | Gearbox option |
|------------------------|-----------------|---|
| From 1.5 to 4 | 28.16 R | TB172 Hydrostatic single speed |
| From 5 to 8 | 28.25 R | TB172 Hydrostatic single speed |
| From 9 to 11 | 28.32 R | TB172 Hydrostatic single speed |
| From 12 to 15 | 28.48 R | TB172 Hydrostatic single speed Input planetary drive |
| From 16 to 19 | 28.60 R | TB172 Hydrostatic single speed Input planetary drive |
| From 20 to 25 | 28.80 R | TB172 Hydrostatic single speed Input planetary drive |

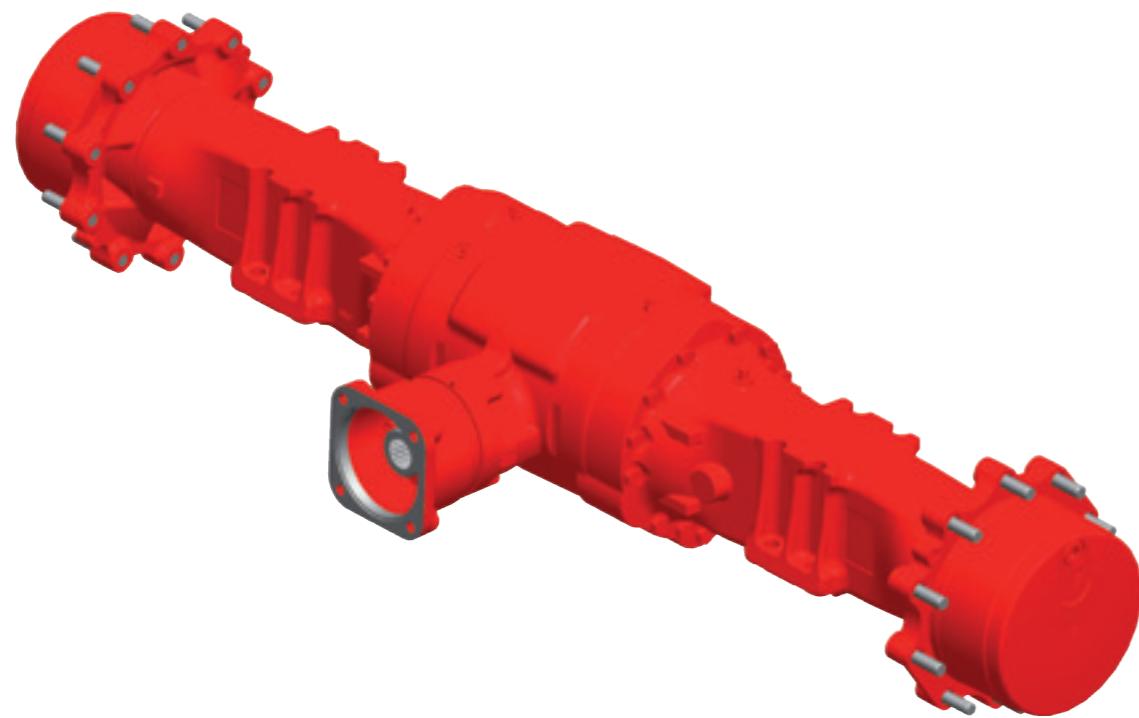

| MODEL | | 28.16 R | 28.25 R | 28.32 R |
|---------------------------|-----|-----------------------------|-----------------------------|------------------------------|
| Overall width | mm | 1,260 | 1,512 | 1,860 |
| Flange to flange distance | mm | 1,100 | 1,270 | 1,654 |
| Wheel mounting dimension | | n° 8 M18x1.5 on 275 mm ø | n° 8 M18x1.5 on 275 mm ø | n° 10 M22x1.5 on 335 mm ø |
| Total reduction | | From 30 to 110 | From 40 to 110 | From 40 to 110 |
| Peak torque | kNm | 22.5 | 35 | 45 |
| Dynamic load capacity | kN | 50 | 80 | 90 |
| Static load capacity | kN | 125 | 200 | 225 |

| MODEL | | 28.48 R | 28.60 R | 28.80 R |
|---------------------------|-----|------------------------------|------------------------------|------------------------------|
| Overall width | mm | 1,988 | 1,928 | 2,040 |
| Flange to flange distance | mm | 1,700 | 1,640 | 1,740 |
| Wheel mounting dimension | | n° 10 M20x1.5 on 335 mm ø | n° 10 M20x1.5 on 335 mm ø | n° 12 M22x1.5 on 425 mm ø |
| Total reduction | | From 43 to 110 | From 43 to 110 | From 43 to 110 |
| Peak torque | kNm | 67.2 | 84 | 112 |
| Dynamic load capacity | kN | 90 | 110 | 120 |
| Static load capacity | kN | 225 | 275 | 300 |

Note

For soil compactors Carraro also offers a full range of hydrostatic drives for the front drum.

The Power Transmission Excellence
is our Passion

Carraro Drive Tech Spa
Headquarters

Via Olmo, 37
35011 Campodarsego
(Padova), Italy
T +39 049 9219111
F +39 049 9289111
webinfo@carrarodrivetech.com

Project related installation drawings
can be made available on request as dimensions
and technical data are subject to change
due to continuous development.



carrarodrivetech.com